

Genetics Review

	1. Dominant	A. An organism having a pair of identical alleles for a gene (PP or pp)
	2. Recessive	B. Genes inherited on the X or Y chromosome
	3. Allele	C. An organism's traits or physical appearance (purple or white flowers)
	4. Homozygous	D. Gets masked or dominated by another factor (trait)
	5. Heterozygous	E. Chart used to predict the probability that certain traits will be inherited in the offspring
	6. Phenotype	F. Two or more genes influence the expression of a single phenotypic character.
	7. Genotype	G. The F ₁ hybrids have an appearance somewhere in between the phenotypes of the two parental varieties (blending of traits)
	8. Punnett Square	H. Genes that exist in populations in more than two allelic forms
	9. Complete dominance	I. A family history that shows how a trait is inherited over several generations
	10. Incomplete dominance	J. Both alleles for a gene are expressed in the offspring
	11. Co-dominance	K. Different versions of a trait
	12. Sex-linked traits	L. An organism's genetic makeup (PP, pp, or Pp)
	13. Multiple Alleles	M. One allele hides the expression of another allele
	14. Polygenic Inheritance	N. Masks or dominates another factor (trait)
	15. Pedigree Analysis	O. An organism having two different alleles for a gene (Pp)

Short Answer

1. What was the name of Mendel's **starting generation**, **first offspring generation**, and then **second offspring generation**?
2. What type of pollination did Mendel use to get his first offspring generation? *Self-pollination or Cross-pollination*
3. Which of Mendel's laws states that during formation of gametes (sex cells), the two alleles for a trait separate? *Law of segregation or Law of independent assortment*

4. Using the following traits to complete Mendel's monohybrid crosses, then **label the generations on the Punnett Squares.**

D = purple flower

d = white flower

- a. homozygous dominant parent crossed with a homozygous recessive parent

Genotype:

Phenotype:

- b. heterozygous parent crossed with a heterozygous parent

Genotype:

Phenotype:

5. Cross a heterozygous parent for both traits with a heterozygous parent for both traits. Use B= brown eyes, b= blue eyes, D= dimples, d= no dimples. Determine the phenotype ratios for this cross.

6. Solve the following Multiple Allele blood type problems

a. Cross AB with BO. Show the genotype and phenotype ratios.

b. Cross AO and BO: Show the genotype and phenotype ratios.

c. Cross OO and AB: Show the genotype and phenotype ratios.

d. If a son has blood type O and his mother has blood type A (with a genotype of AO, what are the only genotypes and phenotypes the father can have.

7. Determine the **genotypes** for all the people in the pedigree using the **letters R and r**.

a. This is a pedigree of a recessively inherited disorder

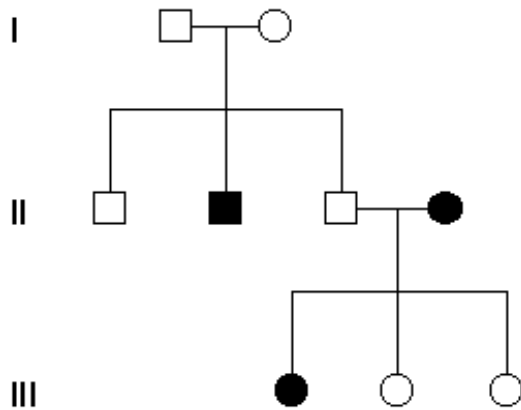

b. This is a pedigree of a dominantly inherited disorder

